

## **Welcome internationals!**

Here you will find some hints for your first steps in Germany.

Table of contents:

1. What do you need to do before you come to Germany?	Page 2
2. How to get from airport Frankfurt to Ludwigshafen / Mannheim?	Page
3. What formalities have to be dealt with during the first few days in Germany?	Page 2
4. Which authorities have to be consulted?	Page 2
5. Foreigner's registration office / resident's registration office in Ludwigshafen	Page 3
6. Work permit/Job opportunities	Page 4
7. Health insurance	Page 4
8. Liability insurance	Page 5
9. Further help in Ludwigshafen	Page 5
• Help for migration and integration	
• Important emergency phone numbers	
• Contact regarding language courses	
• Driving license in Germany	

## What you need to do before you come to Germany?

1. Visa for Germany: please contact the embassy at least 3 months before the beginning of the semester for necessary documents. You can also turn to us if you need support.
2. Apply for Halls of residence or private accommodation in Ludwigshafen.
  - a. Heinigstr. 13, 67059 Ludwigshafen, Germany  
Contact partner: Ms. Schmalenberg, phone +49 6341/917925  
<http://www.fh-ludwigshafen.de/studwohn/wohnheim.htm>  
Rent of room: ca. 210.00 - 235.00 EUR /Month  
Deadline for application: at least 2 Months before the beginning of the semester.  
Prerequisites: 300 EUR Caution + 2 Months rents **(to pay before the arrival in Ludwigshafen!)**  
please notice, that in your room you will have: 1 wardrobe, 1 bed, 1 desk, 1 desk lamp, 1 chair, books frame. (Kitchen: fridge and cooker / hotplate).  
What **you won't have in your room** is: any blanket, any pillows, any bed cover, any pots, any glasses, any plates etc.  
The rental contract is made always for 6 month.  
The price includes all costs (energy, water, internet etc.)
  - b. Rheingönheimer Str. 127/129, 67065 Ludwigshafen  
Rent of single room: 200 EUR /Month  
Rent of apartment: 220 EUR /Month  
Deadline for application: at least 2 Months before the beginning of the semester.  
Prerequisites: 255.65 EUR Caution + 2 Months rents
  - c. Hafenstr. 35-45, 68159 **Mannheim**, Germany  
Contact partner: Mrs. Liehman, phone +49 621/292-1721  
<http://www.hafenstr.de/>  
Rent of apartment: ca. 210-230 EUR /Month  
Deadline for application: at least 2 Months before the beginning of the semester.  
Prerequisites: 450 EUR Caution + 1 Month rents **(to pay before the arrival in Ludwigshafen!)**  
please notice, that in your room you will have: 1 wardrobe, 1 bed, 1 desk, 1 chair, books frame. (Kitchen: fridge and cooker / hotplate).  
What **you won't have in your room** is: any blanket, any pillows, any bed cover, any pots, any glasses, any plates etc.  
The rental contract is made always for 6 month.  
The price includes all costs (energy, water, internet etc.)
  - d. **Private accommodations:** divers, not reservation possible.

If you want to find something else you can search on your own. If there are not enough places in student resident hall I will try to find a place to live in one stu-

dent hall in Mannheim. If they have no places you need to find something on your own.

There are 2 possibilities to find place to stay.

1. **Rent a flat** – you maybe find more students a common flat and stay there together. Please notice that in that case you need to buy the furniture, kitchen equipment, washing machine etc. You can also find a flat with furniture, but you need to pay more for that. (costs for the flat: from 700.00 – 1,200.00 € / month plus deposit)
2. **Wohngemeinschaft** – so called **WG** – this is very popular form of living for students. You do not rent the whole flat but only one room. You are living in a normal house in the city (no student resident hall) but in a common flat (common kitchen, common bathroom). The room is mostly without furniture, but the rest is already there (kitchen, washing machine etc.) (costs for room: 190.00 – 300.00 € / month plus deposit)

Here some internet pages:

<http://mieten.immonet.de/wg/baden-wuerttemberg/mannheim.html>

<http://www.wg-gesucht.de/>

<http://www.studenten-wg.de/>

[http://www.wg-welt.de/suche\\_wg/index.html](http://www.wg-welt.de/suche_wg/index.html)

<http://www.easywg.de/>

[http://www.studenten-wg.de/gesuche\\_lesen.html](http://www.studenten-wg.de/gesuche_lesen.html)

## **How to get from airport Frankfurt to Ludwigshafen / Mannheim?**

Below you will find a plan of the Frankfurt airport. You will arrive probably in Terminal 2 (in D).

You need to get to Terminal 1 – to the All Rail Terminal – **Long-distance trains**

Maybe you need to take a shuttle bus – please inform yourself at the airport.

To find the Long-distance trains please follow the signposting at the airport or ask at the information point.

You need to buy a ticket for the train (costs about € 22.00). You can do it at the automatic ticket machine or buy them over the counter.

You need to take a train to MANNHEIM. Please don't be worry the German trains connections are very comfortable and not overcrowded. It is very easy to get from airport to Mannheim.

From Mannheim you can easy take a tramp to Ludwigshafen.

The University will organise someone who will pick you in Mannheim up and take you to your place.

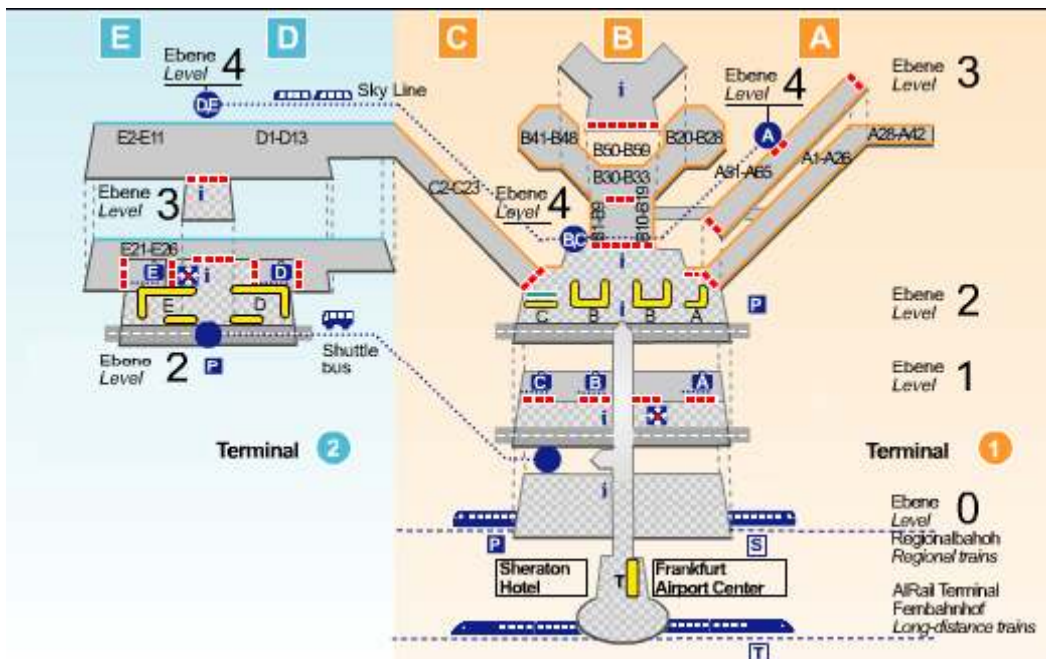
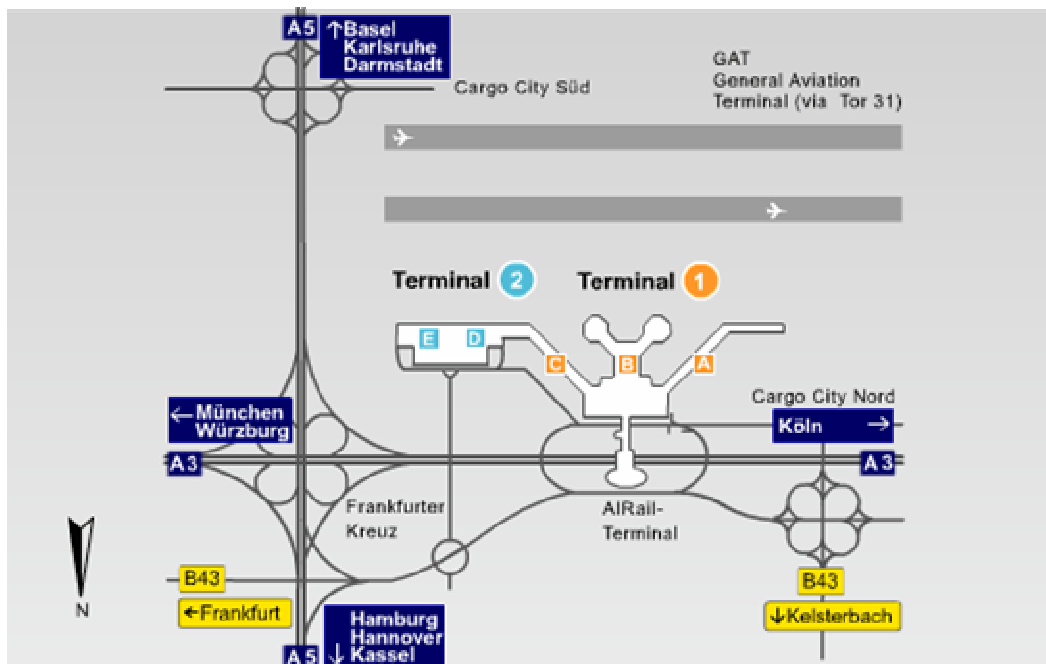

## What formalities have to be dealt with during the first few days in Germany?

1. Registration at the foreigners' registration office. It is absolutely necessary to provide evidence of health insurance.
2. Registration at the residents' registration office. This may be dealt with for you by the foreigners' registration office.
3. The registration office may require a health certificate to be issued by a doctor in Germany. Whether a foreign health certificate is recognised depends on each individual case. Do not have the medical examination carried out until you are explicitly required to do so. Many towns have public health centres, which carry out such examinations relatively cheaply. Some federal states in Germany require an HIV test.
4. Open a current account at a bank, savings bank or the post-office bank. To open an account some banks (including the post-office bank) require proof of registration at the residents' registration office as well as the residence permit. It is advisable to set up a direct-debit authorisation for the monthly payments to be made to your health insurance to cover the full duration of your stay.

## Which authorities have to be consulted?

It is best to get unpleasant matters dealt with as quickly as possible. In Germany these are the tiresome but necessary visits to the authorities. As a rule the first of these visits for foreign students is to the foreigners' registration office<sup>1</sup> in the town of residence.

Everyone has to apply personally for a residence permit. It is also at this office that students have to show that they are financially secured for the period of their stay. This means: the student has to have at his/her disposal at least € 500 per month. The application is approved upon presentation of the following documents:

- valid students' visa (for students coming from countries outside the EU),
- completed application form (available from the university foreigners' office),
- valid passport or identity card,
- proof of health insurance,
- copy of the rental contract or confirmation signed by the landlord,
- three passport photographs
- and in some cases a medical certificate.

The residence permit is normally issued for one year and is to be renewed annually.

The next visit is to the residents' registration office<sup>2</sup>, unless the foreigners' registration office deals with this step for you.

<sup>1</sup> State authority at which nationals of non-EU countries have to apply for a residence permit prior to the expiry date of their entry visa. The residence permit is issued for one year in each case and has to be renewed annually. The foreigners' registration office is also the authority at which application is made for a *work permit* and which can give foreign students approval for working time exceeding the official work-time contingent of 90 days per year (a maximum of 10 hours a week).

<sup>2</sup> Municipal authority which registers the residents of a specific district. The place of residence has to be registered here within one week and in the case of a move to another flat the authority has to be notified of the new address.

Anyone wanting to live in Germany for more than three months has to register his/her place of residence within one week. A copy of the [rental contract](#) for the flat or a corresponding confirmation signed by the landlord is required for registration. Re-registration is necessary if, for example, a move is made to another flat. Important: as the registration authorities are not always located in the same municipal offices please ask the university foreigners' office for the correct address.

## **Foreigners' registration office / residents' registration office in Ludwigshafen**

At the beginning of your study period please go to the foreigners' registration office. You will be given an application form to complete and will also have to present a confirmation signed by your landlord (confirmation of rental agreement) or the rental contract. As a rule the foreigners' registration office will deal with the formalities at the residents' registration office for you.

Ausländerbehörde Ludwigshafen am Rhein,  
 Abteilung Aufenthaltsrecht  
 Marienstraße 8  
 67063 Ludwigshafen am Rhein

Opening times of the foreigners' registration office in Ludwigshafen am Rhein:  
 Mondays, Tuesdays, Fridays from 8.00 to 12.00 and Thursdays from 8.00 – 12:00 as well as from 14.00 – 18.00.

Information can be obtained from the foreigners' registration office in Ludwigshafen by telephone under the following numbers (sorted according to the first letter of the surname):

0621 504-33 30	A – BOQ
0621 504-20 31	BOR –D
0621 504-20 28	E – H
0621 504-20 24	I – KK
0621 504-33 58	KL – MI
0621 504-20 39	MJ – RH
0621 504-20 44	RJ – TN
0621 504-20 38	TM – Z

## **Work permit/Job opportunities**

As a student of I-IMC, you do not need a work permit, if you wish to work during your course of studies. Please ask the citizens' service centre at the town hall to issue an income tax card for you. Without this card you cannot enter into any employment in Germany. You will also need a written confirmation and other documents from us. Please ask us in advance.

There are good chances for well-qualified internationals to find an internship or a regular job with one of the numerous companies settled in or closed to Ludwigshafen such as BASF, DaimlerChrysler, JohnDeere, ABB, Südzucker etc. Even though most of these companies are international companies and correspond mostly in English it is important to have at least basic knowledge of German. Therefore it is very helpful if

you start learning German in your home country and continue with the language course offered by I-IMC to improve the language skills.

## Health insurance

All students require health insurance. Membership in a health insurance scheme is a prerequisite for a course of studies at the University of Applied Sciences. The statutory health insurance contribution for students amounts to approximately € 60.00 per month. For students over 30 years € 104.00 (in the first 6 month) or € 135.00.

Please contact the health insurance company of your choice for help and ask them to give you information on the benefits and insurance cover to which students are entitled. If you decide to join a private health insurance scheme it will not be possible to change later to the statutory health insurance fund.

Here are some addresses of health insurance companies in the vicinity:

DAK, Rathausplatz 10, 67059 Ludwigshafen, Tel. +49 (0)621 59603-0  
 DAK, Augustaanlage 7-11, 68165 Mannheim, Tel. +49 (0)621 1587-0  
 Barmer EK, Kaiser-Wilhelm-Str. 7, 67059 Ludwigshafen, Tel. +49 (0)621 59003-0  
 Barmer EK, Stadthaus N1-Podium, 68161 Mannheim, Tel. +49 (0)621 1700-530  
 AOK, Kurfürstenstraße 11, 67061 Ludwigshafen, Tel. +49 (0)621 56170

## Liability insurance

We also recommend taking out a liability insurance to cover damage for example in your place of residence, in sports and as a road user. Please ask several different insurance companies about the range of cover available.

## Further help in Ludwigshafen

Help for migration and integration!

AWO Stadtkreisverband Ludwigshafen  
 Maxstraße 65  
 67059 Ludwigshafen  
 Phone 0621 518014

## Important Emergency-Phone-Numbers

Police	110
Fire department	112
Medical emergency	0621 5929999

## **Contact regarding language courses**

“Akademisches Auslandsamt” (office for foreign affairs) at the University of Applied Sciences in Ludwigshafen, 4. Floor, room 401

or

VHS Ludwigshafen  
Im Bürgerhof  
67059 Ludwigshafen

Phone +49 621 5042632

<http://www.vhs-lu.de/>

## **Driving License in Germany**

If you have a driving license in your original country out of EU, you may drive with it with an official translation in Germany for max. 6 months after your entry into Germany. After this period, your driving license will be invalid and you have to rewrite it into a German one.